



 **BULOVA**
ACCUTRON

**Service
Manual
Series 230**

Table of Contents

	Page Number
Section I	
Introduction to and Technical Characteristics of Accutron®	
Series 230	1
Special Tools and Equipment	2
Terminology and Meter Settings	3
Testing and/or Replacing the Power Cell	4
Regulation	5
Diagnostic Procedures	6 & 7
Special Points for the Repairman	8
Checking Freedom and Endshake of the Train	8
Testing the Hack Mechanism	8
Checking Phase	8
Testing the Electronic Circuit	9
Section II (Model 2300)	
Removing Movement from Case	10
Disassembly of Dial Train	10
Disassembly of Gear Train	11
Cleaning the Movement	12
Reassembly of the Gear Train	13
Meter Testing of the Coil and for Free Fork	14
Checking and Adjusting of Hack Mechanism	14
Installation of Wheels and Bridges	14
Adjusting Tuning Fork Clearance	15
Lubricating Dial Train	16
Assembling Dial Train	16 & 17
Adjusting Indexing Mechanism	18
Preposition & Engagement of Index and Pawl Fingers	18
Phasing	19
Casing of the Movement	19
Checking Movement in Case	19
Parts List Model 2300	20 & 21
Section III (Model 2301)	
Model 2301 and Parts	22
Section IV (Model 2302)	
Model 2302 and Parts	23 & 24

PATENT NOTICE

The BULOVA ACCUTRON® timepiece is manufactured by Bulova Watch Company, Inc. under issued patents as well as pending patent applications, including the following patents:

U. S.	2,888,582; 2,971,323; 3,162,006; 3,184,981; Re. 26209; 3,257,794; 3,221,190; 3,262,259; 3,421,310; 3,421,311
Canada	576,917; 609,691; 764,176; 756,819; 685,419
France	1,102,373; 74,802; 70,710; 1,491,231; 1,473,353; 1,322,145
Germany	971,059; 1,095,747; 1,124,433
Great Britain	761,609; 797,851; 840,086; 854,196; 955,559; 1,064,230; 1,074,104
Switzerland	312,290; 333,403; 342,171; 353,311
Italy	517,679; 558,253; 552,682; 591,162; 683,351
The Netherlands	228,637
Mexico	60,653; 59,196
Japan	249,402; 301,465; 485,526; 249,885; 246,248; 246,254

All information contained herein is based on the latest product information available at the time of printing. The right is reserved to make changes at any time without notice.
Copyright © 1966, 1969, 1973, Bulova Watch Company, Inc. All rights reserved.

* "ACCUTRON," "BULOVA," "WATCHMASTER" and "  " are registered trademarks of Bulova Watch Company, Inc.

Introduction to and Technical Characteristics of Accutron® Series 230

SECTION I

This manual contains detailed and complete instructions for the maintenance and repair of Accutron movements Series 230. You will notice that maintenance and repair of Accutron movement series 214, 218 and 230 are basically the same.

WHENEVER POSSIBLE FIND OUT EXACTLY WHAT THE CUSTOMER'S PROBLEM IS **BEFORE** YOU ATTEMPT CORRECTION.

Caution: Due to the engagement of the hack pin, care should be taken that the watch which contains a cell is **not** put into stock with the **stem in setting position**. This will cause the cell to become exhausted within a relatively short time of approximately two months. This series does **not** have a power cell disconnect system.

Technical Characteristics:

Movement: 8¾ or 10½ ligne electronic tuning fork.

Tuning fork frequency: 480 oscillations per second.

Jewels: thirteen

Index wheel teeth: 240

Hack setting

Instantaneous manual date change

Energy source: "Accutron 218" power cell

Pillar plate: 19.4mm (8¾ ligne) or 23.3 mm (10½ ligne)

Height of movement: 5.2mm

Hands: hour hand hub 1.40mm

minute hand hub 0.80mm

center second hand pipe 0.18mm

Model 2300: 8¾ ligne without sweep second; without calendar.

Model 2301: 8¾ ligne with sweep second; without calendar.

Model 2302: 8¾ ligne with sweep second; with date.

Model 2303: 8¾ ligne with sweep second; with day/date.

Model 2312: 10½ ligne with sweep second; with date.

Model 2313: 10½ ligne with sweep second; with day/date.

Bulova Watch Company, Inc.
75-20 Astoria Boulevard
Jackson Heights, N.Y. 11370

Bulova Watch Company, Ltd.
105 Bartley Drive
Toronto 16, Ontario, Canada

Bulova Watch Company, Inc.
44 Faubourg DuJura
2500 Bienne 4, Switzerland

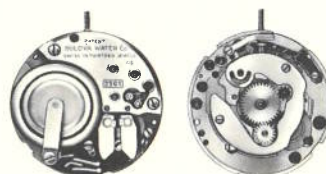

2301

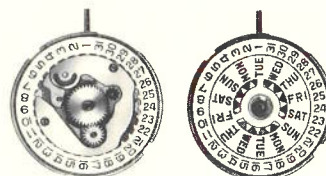

2302

2303

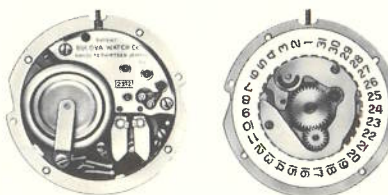

2312



2313

Special Tools and Equipment for Servicing Series 230

- Fig. 1 Single Microscope—9020 (30X)
- Fig. 2* Binocular Microscope (10-30X SM1)
- Fig. 3 Test set model 700—9920/700
- Fig. 4 Power cell Lead
- Fig. 5 Movement Holder 9982
- Fig. 6 Movement Support for applying hour and minute hands—E 32
- Fig. 7 Movement Support for applying sweep second—hand E 31
- Fig. 8 Collet adjusting tool—9981
- Fig. 9 Post bending tool—22010

- Fig. 10 Hack pin bending tool—22009
- Fig. 11 Regulating wrench #22007
- Fig. 12 Wrench for water resistant cases (stainless steel tubular) 2300-
- Fig. 13 Wrench for water resistant cases (plastic for gold cases) 2300-

Note: The tools and equipment pictured below are available through our Watchmaster representative in your area, or through your local Bulova Material Jobber. For further information write to:
 Bulova Watch Co., Inc.
 Technical Information Services
 62-10 Woodside Avenue
 Woodside, New York 11377

** Available only from Watchmaster Products at the same address as above, or through the Bulova general agent in your country.*

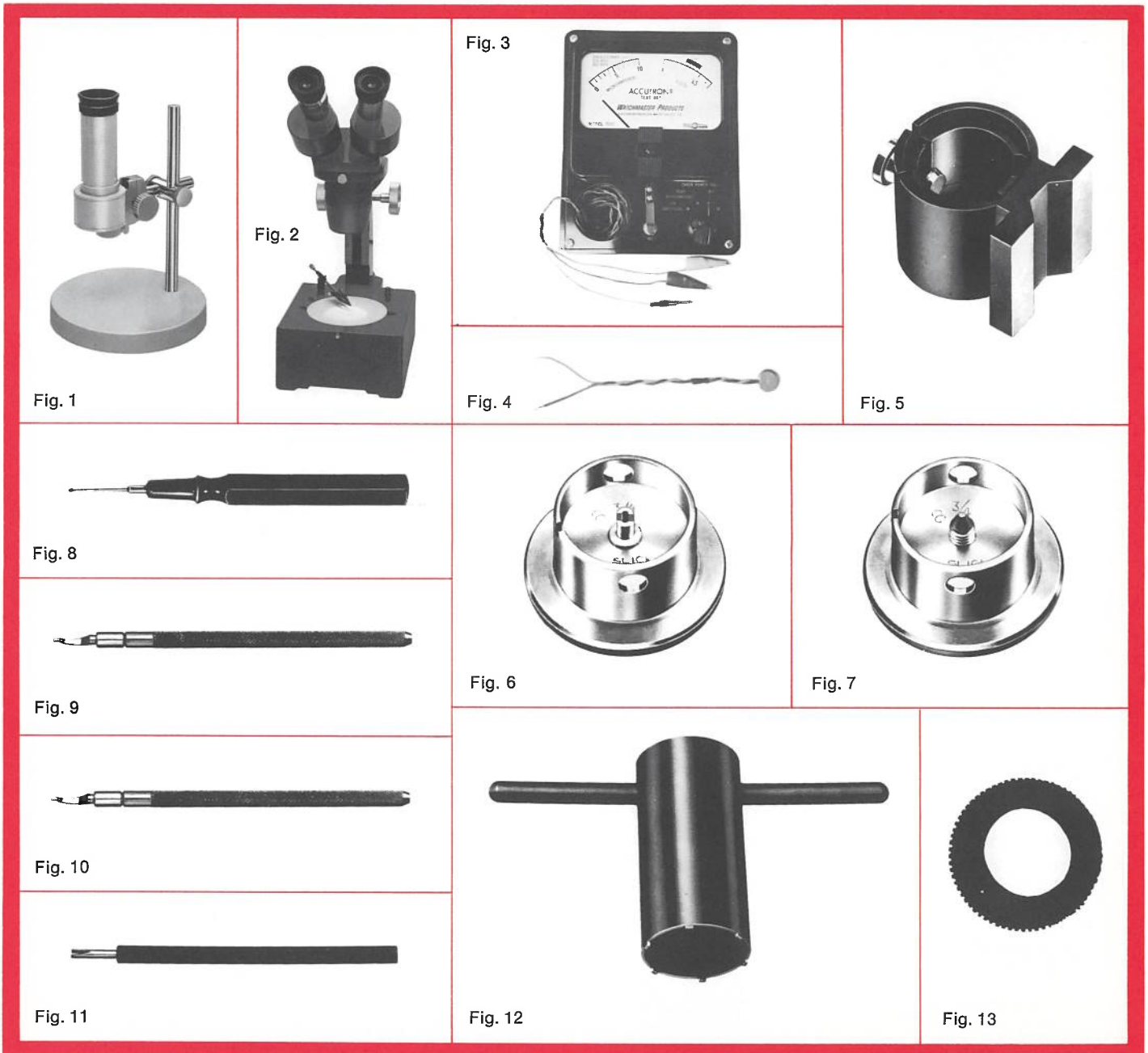

Terminology

AMPLITUDE	<i>Distance</i> the tine of the fork travels.
ENGAGEMENT	Application of tension of the fingers against the index wheel.
FREQUENCY	<i>Rate</i> at which the tuning fork vibrates or number of vibrations per second (Hz).
OPEN CIRCUIT	A circuit which does not provide a path for the flow of current: (meter reads zero)
OVERAMPLITUDE	Index finger jewel picking up and advancing more than one tooth of the index wheel at a time.
OVERSTRESSED TUNING FORK	Slow rate (frequency) created by watch receiving a severe external blow or by being dropped from a high point to a hard surface.
PHASE	Placing the pawl finger jewel in proper relationship to the index finger jewel by turning the phasing screw.
PREPOSITION	Disengaged position of the fingers prior to engaging into index wheel.
SHORT CIRCUIT	An abnormal connection between two points (meter pegs).
TINE	Arm of the tuning fork.

Meter Settings

LOW AMPLITUDE	For phasing at reduced voltage. Not for meter readings.
READ MICROAMPERES	Checking current consumption (drain)
CELL TEST	Checking for cell voltage.

Accutron Service Kit Model 700*

This kit is a must for servicing all Bulova Accutron movements. It contains movement holders, wrenches, adjusting tools and service manuals for all Accutron movements including the new Bulova Ladies Accutron series 230. It quickly and accurately checks the condition of the power cell and current flow under actual operating conditions allowing you to make an immediate diagnosis and adjustment. All readings are taken from a clearly marked scale showing the movement's condition, instantly.

Includes a complete set of tools for servicing all Accutron models. (Fig. 14)

*One year guarantee.

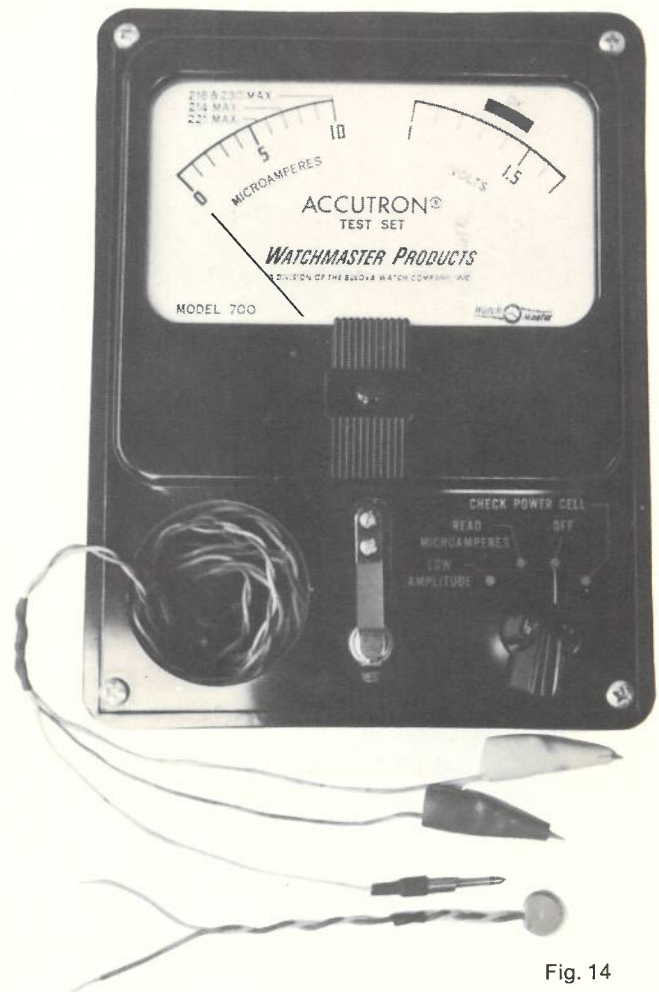

Fig. 14

Testing and/or Replacing the Power Cell

WHENEVER POSSIBLE FIND OUT EXACTLY WHAT THE CUSTOMER'S PROBLEM IS *BEFORE* YOU ATTEMPT CORRECTION.

CAUTION: CLEAN WORK AREA AND CASE BACK BEFORE OPENING CASE.

Removing Cell:

1. Open case by unscrewing the back or threaded ring with the help of a wrench, then remove back. For slotted case backs, apply a knife type case opener at the notch provided for this purpose. For special cases refer to technical letters covering the subject. Remove back.
2. Loosen cell strap screw (304) 1½ turns.
3. Move cell strap away from movement.
4. Remove cell. (Fig. 15)

Testing 218 Power Cell

1. Place the Power Cell with the printing **down** in either the nest of Test Set model 700 or the Bulova Cell Tester model 220. (Not shown).
2. When using the model 700 it will be necessary to turn selector switch on Test Set to "CHECK POWER CELL" position. (Page 3 "METER SETTINGS").
3. Read Power Cell voltage on right-hand scale. The voltage reading should be in the "OK" area of the scale (1.25 to 1.45 volts). If it is, Power Cell is in satisfactory operating condition. If not replace cell.

Note: Poor electrical contact between Power Cell and Test Set will cause either a "zero", low or a wavering indication of cell voltage. It can be readily avoided by making certain that Power Cell surfaces and contacting points of the Test Set nest and clip are clean. Rubbing or twisting a suspected cell between the contacts before checking voltage is good practice. A wavering reading of voltage is always an indication of poor contact, not an indication of a bad cell.

Caution: Never use substitute cells in place of the genuine "ACCUTRON 218" Power Cell. Though other cells may look the same, they may not reliably operate this model timepiece and may, in some instances, seriously * damage the movement. The only genuine Power Cell has "ACCUTRON 218" imprinted on it.

Replacing the Power Cell

1. Clean underside of cell strap.
2. Install the power cell (*printing down*) in cell well of movement. (Fig. 15)
3. Reposition cell strap and tighten screw.
4. If water resistant case, make sure the gasket is properly seated.
5. Replace Case back.

***AN INITIAL SAVINGS OF PENNIES MAY CREATE A COST OF MANY DOLLARS LATER SINCE DAMAGE CAUSED BY USE OF SUBSTITUTE CELL IS NOT COVERED UNDER WARRANTY.**



Fig. 15

Regulation

The accuracy of the tuning fork Accutron Series 230 is such that a correction of more than 2 minutes per week usually requires a repair and not regulation. The regulators (fig. 16) are moved to correct the error. The range of both regulators is a total of 32 seconds per day. Moving one regulator one graduation is equal to a correction of four (4) seconds per day.

Method of Regulating:

Accutron rate (frequency) is checked in dial position only and regulated to zero "0" rate. A tolerance of -1 to $+1$ second a day is acceptable.

If customer returns a watch for regulation, indicating that it gains or loses beyond the guaranteed limits, proceed as follows:

1. Check the rate of the watch with an Accutron Rate Recorder, B 100A-B 200A (Vibrograf) (fig. 17) before opening the case. Compare the result with the customer's report making sure that there is no discrepancy. (Gains instead of losing or vice versa).
2. Open the case as instructed on page 4.
3. To correct the tuning fork rate, move regulators as shown in figure 16. One or both regulators can be moved. It is recommended to move each regulator half the amount of correction.
4. If the timing rate is beyond regulation and the problem is not mechanical, e.g. Metal particles on magnets, partial fork obstruction, etc. the tuning fork may have been overstressed and/or damaged and should be replaced.

The Bulova Vibrograf B200A is the only time testing device recommended by Bulova for testing tuning fork movements including the new model Accutron[®]s by Bulova. It incorporates all the latest technological advances—solid state circuitry, modular construction and a hermetically sealed quartz crystal for utmost accuracy.

Yet, with all its advanced features, the B200A is remarkably easy to use. Just place the timepiece on the holder and the Vibrograf starts printing a clear crisp image. No warm-up time is needed. Take the watch off and the system stops.

Features:

- All-transistor solid state circuitry. No tubes to burn out. No warm-up time.
- Modular construction. Parts can be popped in and out for fast easy service.
- Permanent pressure sensitive paper. No messy ink ribbons. Rate is graphically recorded in a crisp sharp image.
- Automatic paper feed system. Paper feeds only when timepiece is on the watch holder.
- The Bulova Vibrograf is the only rate recorder we recommend to check tuning fork movements.

For further information write to:
WATCHMASTER PRODUCTS
Div. of Bulova Watch Company, Inc.
62-10 Woodside Ave.
Woodside, N.Y. 11377

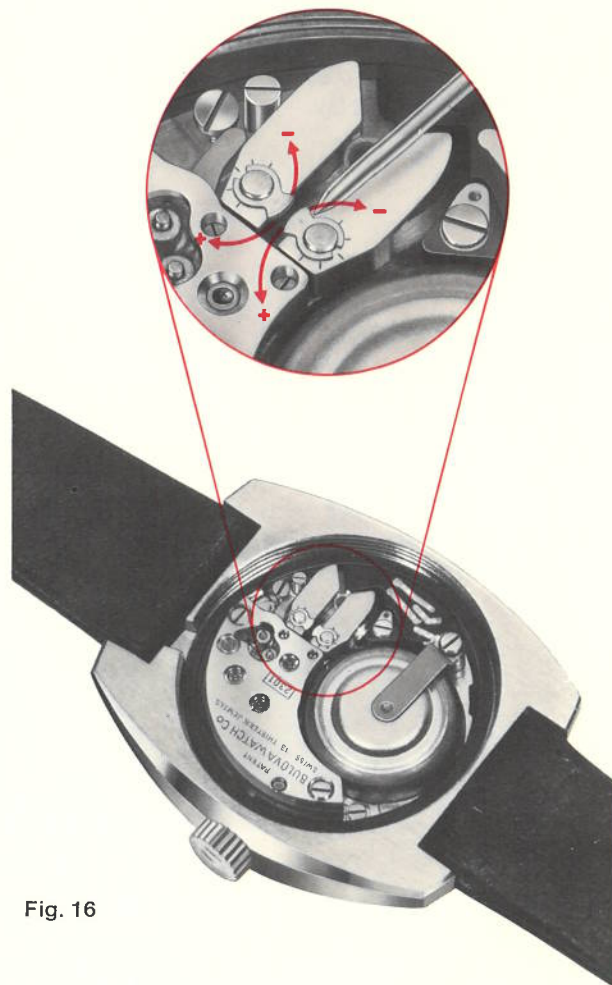

Fig. 16



Fig. 17

Symptom	Possible Causes (In order of Probability)	Diagnostic Procedure	Corrective Action Required
Gaining or losing a few seconds per day.	Unusual wearing habits or improper regulation	No diagnosis required.	Regulate (page 5).
Irregular Day-To-Day Rate (gains a few seconds per day, loses a few seconds the next, etc.	Inaccurate source of time for checking Accutron rate.	Determine source of time used for checking performance.	Recommend (a) checking performance over 1 month period in keeping with guarantee, or (b) use of accurate time source for daily checking. (Short wave WWV or CHU Canada)
Gaining or Losing Excessively (minutes per week)	<ol style="list-style-type: none"> Hands rub or catch slightly. Poor contact between cell strap and Power Cell. Indexing mechanism out of adjustment. Mechanical interference with free vibrations of fork. Train partially blocked. Damaged teeth on index wheel. 	<p>Check crystal clearance. Inspect for adequate clearance between hands and between hands and dial markers or crystal.</p> <p>Inspect Power Cell and cell strap for an adherent deposit of dried electrolyte which may sometimes "push" the cell strap away from the Power Cell.</p> <p>Check adjustment of indexing mechanism (page 18).</p> <p>Check movement current (page 9). If current is above OK range, rotate index finger collet to disengage jewel from index wheel. If current remains above OK range fork may be blocked or partially demagnetized. "Special Points" page 8.</p> <p>If movement current was above normal in step 4 (above) but current is OK with index mechanism disengaged, train is partially blocked. Check train freedom (page 8).</p> <p>See "Special Points" (page 8), item 3.</p>	<p>Adjust hand clearance. Be sure the sweep hand is not turned in either direction during adjustment.</p> <p>Clean cell strap and replace Power Cell as described on pg. 4 "NOTE"</p> <p>Adjust indexing mechanism, if necessary (page 18). Phasing (page 19).</p> <p>Remove blockage. Readjust indexing mechanism (page 18). Phasing (page 19).</p> <p>Remove blockage. Readjust indexing mechanism (page 18). Phasing (page 19).</p> <p>Replace index wheel assembly procedures (page 14). Check adjustment of indexing mechanism (page 18-19).</p>
STOPPED no hum	<ol style="list-style-type: none"> Exhausted Power Cell. Open Coil Circuit. Mechanical blockage of tuning fork. Faulty Electronic Circuit. Crown in setting position. 	<p>Open case, remove Power cell and check its voltage (page 4). If voltage is low, Power Cell is exhausted.</p> <p>Check movement current (page 9). If no current the coil is "open."</p> <p>If movement current is above OK range in step 2 (above), rotate index finger collet to disengage jewel from index wheel. If current remains above OK range, fork may be blocked.</p> <p>If movement current is high and tuning fork is not blocked, electronic circuit may be faulty. Replace coil assembly if still high replace fork (partially demagnetized).</p> <p>Check to see if crown is pressed "in."</p>	<p>Replace Power Cell (page 4).</p> <p>Replace coil assembly. The coil assembly can be replaced without disturbing the indexing or removing the fork or train wheels (See page 11).</p> <p>Remove blockage. Readjust indexing mechanism (page 18). Phasing (page 19).</p> <p>Replace coil assembly (disassembly procedures (page 11) and reassembly procedures (page 13). Readjust indexing mechanism (page 18). Phasing (page 19)</p> <p>Press crown "in".</p>

Symptom	Possible Causes (In order of Probability)	Diagnostic Procedure	Corrective Action Required
STOPPED	1. Crown in setting ("out") position.	Check to see if crown is pressed "in".	Press crown "in".
	2. Power Cell voltage low.	If crown is "in", open case, remove Power Cell and check its voltage (page 4). If voltage is low, Power Cell is exhausted.	Replace Power Cell (page 4).
STOPPED Sweep Second hand does not turn but fork hums	1. Hack mechanism out of adjustment.	Remove movement from case and place in movement holder. Check adjustment of hack mechanism (page 8).	Adjust hack mechanism (page 14).
	2. Indexing mechanism out of adjustment.	Check adjustment of indexing mechanism (page 18).	Adjust indexing mechanism (page 18). Phasing (page 19).
	3. Mechanical interference with free vibrations of fork.	Check movement current (page 9). If current is above OK range rotate index finger collet to disengage jewel from index wheel. If current remains above OK range fork may be partially blocked.	Remove blockage. Readjust indexing mechanism (page 18). Phasing (page 19).
	4. Mechanical blockage of train.	If movement current was above normal in step 5 (above) but current is OK with index mechanism disengaged, train is partially blocked. Check train freedom (page 8).	Remove blockage. Readjust indexing mechanism (page 18). Phasing (page 19).
	5. Dirt in teeth of index wheel.	If above checks prove negative, connect test set with switch in "read microamperes" position. With crown "in", tap movement holder with finger to increase fork amplitude while observing closely with loupe. If index wheel rotates once, then stops again, there may be dirt in index wheel teeth.	Remove index wheel (disassembly procedure (page 11). Clean wheel and reassembly (page 13). Readjust indexing mechanism (page 18). Phasing (page 19).
	6. Damaged teeth on index wheel.	If test in step 7 (above) proves positive but is not corrected by cleaning index wheel, index wheel teeth have been damaged. Replace index wheel.	Replace index wheel (disassembly procedures page 11) and reassembly procedures (page 13). Readjust indexing mechanism (page 18). Phasing (page 19).
STOPPED Hour and minute hands stopped but sweep second hand turns.	1. Hands catch.	Inspect for adequate clearance between hands and between hands and dial markers.	Adjust hand clearance. Be sure the sweep hand is not spun during adjustment to avoid damaging indexing mechanism.
	2. Stoppage in dial train.	If hand clearances are satisfactory, remove dial and hands (pg. 10). Inspect for foreign matter.	Remove blockage.
GAINS EXCESSIVELY Watch gains but Rate O.K. on Rate Recorder	1. Improper Finger Adjustment.	Adjust to proper jewel angle of both fingers.	Adjusting Indexing Mechanism Fig. 48 (page 18).
	2. Light Finger Engagement.	Check for insufficient tension of pawl and index fingers and adjust if necessary.	Preposition and Engagement of Index and Pawl fingers Fig. 44 (page 18).
	3. Improper Index Wheel Endshake.	With cell meter lead connected to mov't. press index wheel cap jewel with pegwood. Increase endshake of index wheel if meter needle shows increase of current.	Checking Freedom & Endshake of the Train Wheels. (page 8).

Special Points for the Repairman

WHENEVER POSSIBLE FIND OUT EXACTLY WHAT THE CUSTOMER'S PROBLEM IS **BEFORE** YOU ATTEMPT CORRECTION.

Remember; To save time, therefore, money, tests and checks should be performed **prior to disassembly** to determine the problem and where it is. This will allow for disassembly only as necessary and possibly not for complete disassembly.

The ACCUTRON movement, being completely different from conventional watch movements, requires different techniques in its repair. Otherwise, it may be damaged by improper procedures on the part of the repairman.

- 1. Removing or Replacing Hands:** For example, turning the sweep second hand or the gear train (in either direction) with the indexing fingers engaged, *will damage the index wheel teeth* or the index and pawl fingers. Check indexing adjustment after replacing sweep hand. (Ref. to pg. 18 Indexing Adjustment and pg. 19 Phase)
- 2. Removing or Replacing Stem:** As with conventional watches the stem should preferably be pulled "out" (setting position) before depressing the setting lever pin to remove the stem.
- 3. Index Wheel:** The teeth on the index wheel will not wear away in normal use, nor can they be damaged as a result of any accident, when the movement is enclosed in its case with the crystal intact. The index wheel can be damaged by improper handling on the part of the repairman. If it is suspected that the teeth on the index wheel have been damaged, the most practical solution is to replace it, since visual examination will rarely disclose the damage—because of the size of the tiny teeth. *Always handle the index wheel by its pinion never by the wheel.*
- 4. Lubrication:** Do **not** oil the *teeth* of the index wheel *nor the index and pawl finger jewels*. The pivot jewels should be oiled only $\frac{1}{3}$ of the diameter of the cap jewel.
- 5. Electrical Contact:** Make a habit of cleaning the underside of the cell strap, which can be done efficiently with an eraser and wiping any white adherent material, if present, from the Power Cell. Such material may sometimes "push" the cell strap away from the Power Cell and thereby break electrical contact. In such instances removing the residue, particularly on the underside of the cell strap, will prevent a latent problem in this regard.
- 6. Circuit:** The use of electrical test equipment or procedures other than those recommended, should be avoided. In particular, circuit elements can be damaged by the use of a Multimeter and/or ohmmeter for testing the circuit.
- 7. Removing or Replacing the Coil Assembly:** A coil assembly can be removed and replaced without disassembling either train or fork nor affecting the indexing mechanism. (Page 11)
- 8. Magnetism:** Never demagnetize an ACCUTRON movement or expose it to high strength magnetic fields (permanent magnets, for example.)
- 9. Magnets Partially Demagnetized:** Experience has shown that demagnetized tuning fork magnets are very rare. If

the movement current is within the "OK" range of the scale on the test set, the magnets are satisfactorily magnetized.

If the tuning fork magnets have lost most of their magnetism, the tuning fork will fail to vibrate and the Test Set will indicate a very high current or pegs—normally interpreted as due to a faulty electronic circuit. If the magnets have lost only a portion of their magnetism, the tuning fork may vibrate but the Test Set will indicate excessive current or above the "OK" range of the scale. In each of these instances, if an excessively high current (and/or failure of the tuning fork to vibrate) cannot be corrected by replacing the complete coil assembly—try substituting a different fork.

- 10. Temperature Affect on Movement:** A slightly higher than normal meter reading may occur as the result of exposing the movement to heat from a lamp—or by being held in the hand for a long time. Allow movement to cool for $\frac{1}{2}$ hour and recheck.

Testing the Hack Mechanism

- The hack pin which is attached to the rocking bar assembly (# 144) has two purposes:
 - To stop the tuning fork during setting of hands.
 - To start the tuning fork when stem is pushed in.The watch must start within five seconds after the crown is pushed in and the hack is properly adjusted. For additional hack adjustment information see page 14.

Caution: Due to the engagement of the hack pin, care should be taken that the watch, which contains a cell, is not put into stock with the stem in setting position. This will cause the cell to become exhausted within a relatively short time, (approximately 2 months).

Checking Phase

Can be performed in or out of case.

Phase check consists of turning phase screw *clockwise* until tight. Connect meter to movement, set selector knob at "LOW AMPLITUDE" and slowly turn phase screw *counterclockwise*. Index wheel should turn without hesitation. If not, refer to instructions in this manual. (page 18 & 19).

Checking Train Freedom

To test for train blockage pull back the tine of the fork which bears the index finger and release it suddenly. This is called "twanging" and is done with a pegwood. The tuning fork will vibrate a few seconds and transmit its movement to the train if it is free. The endshake of the index wheel should be between 0.02 to 0.04 mm.; the other wheel from 0.02 to 0.06 mm.

Calendar Models

Instant date change can be accomplished when the crown is "in" and it is turned *counterclockwise*.

Testing Electronic Circuit

1. Insert cell in test meter # 700, turn rotary switch on Test Set to "CHECK POWER CELL" position. Read Power Cell voltage on right hand scale. The voltage reading should be in the "OK" area of the scale.
2. Turn selector knob to "READ MICROAMPERES".

Caution: The following check must be done with the crown in the "In" position, which disengages the hack.

1. Attach power cell lead to the movement, holding it down with cell strap, tap movement to start the fork vibrating (fig. 18).
2. If reading is zero (0) (fig. 19) the circuit is open and must be replaced. Note: The coil assembly can be removed and replaced without disturbing the train, fork or indexing mechanism. Page 11.
3. For correct reading, meter pointer should *not* be above 10 microamperes with the fingers engaged (fig. 20).
4. If the reading is above 10 microamperes (fig. 21 or fig. 22) *disengage* index finger from index wheel by turning the collet of the index finger.
5. Should the reading remain in the "EXCESSIVE CURRENT" (fig. 21) or "METER PEGS" (fig. 22) area, then the problem lies in the circuit and/or fork area of the movement: e.g. demagnetized fork, foreign matter, binding fork, metal particles clinging to magnets of fork or faulty circuit. A slightly higher than normal meter reading may occur as a result of exposing the movement to heat from a lamp or by being held in the hand for a long time. Allow movement to cool for 1/2 hour and recheck.
6. Check the above possibilities and remove obstruction or replace fork and/or coil as necessary.
7. On the other hand, if disengaging the index finger from the wheel, the pointer drops to 7 microamperes or below (fig. 23) then the problem lies within the gear and/or dial train area.
8. Determine the cause of the problem within the gear and/or dial train and repair as necessary.
9. By disengaging the index finger, as in step 4, it may now be determined whether the problem is within the fork and coil area or within the mechanical area of the movement (fig. 24).

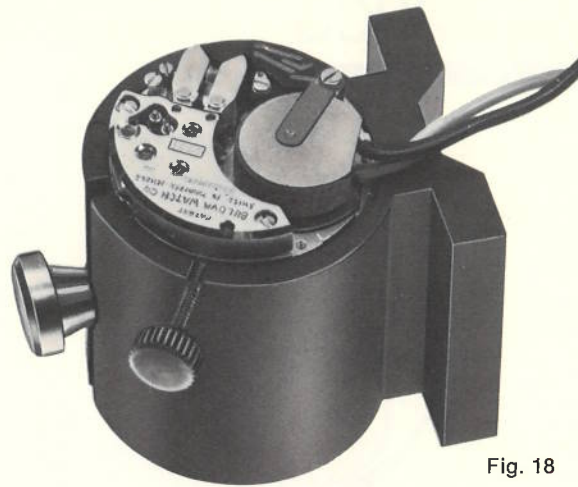

Fig. 18

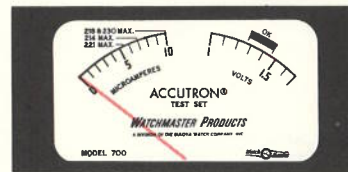

Fig. 19

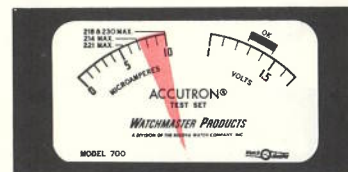

Fig. 20

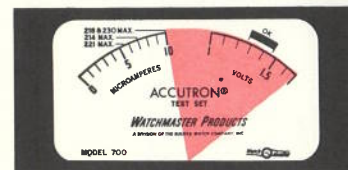

Fig. 21



Fig. 22



Fig. 23

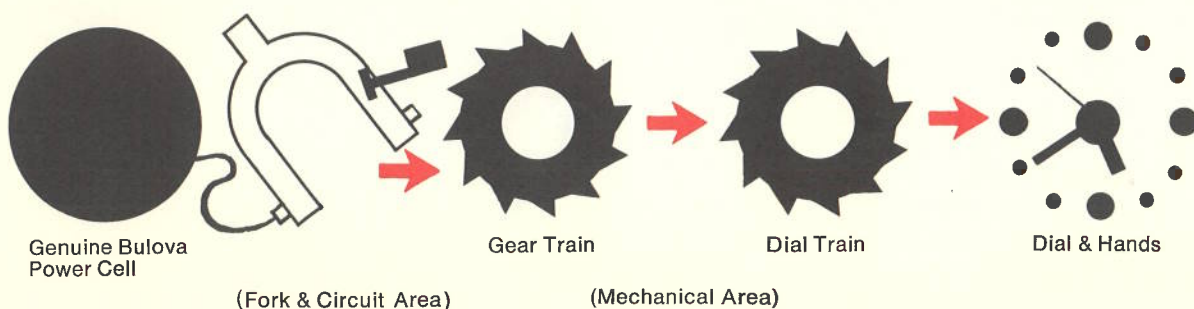

Fig. 24

SECTION II

MODEL 2300

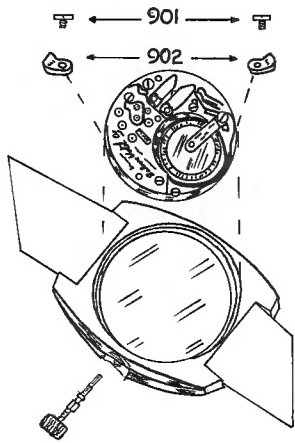

Fig. 25

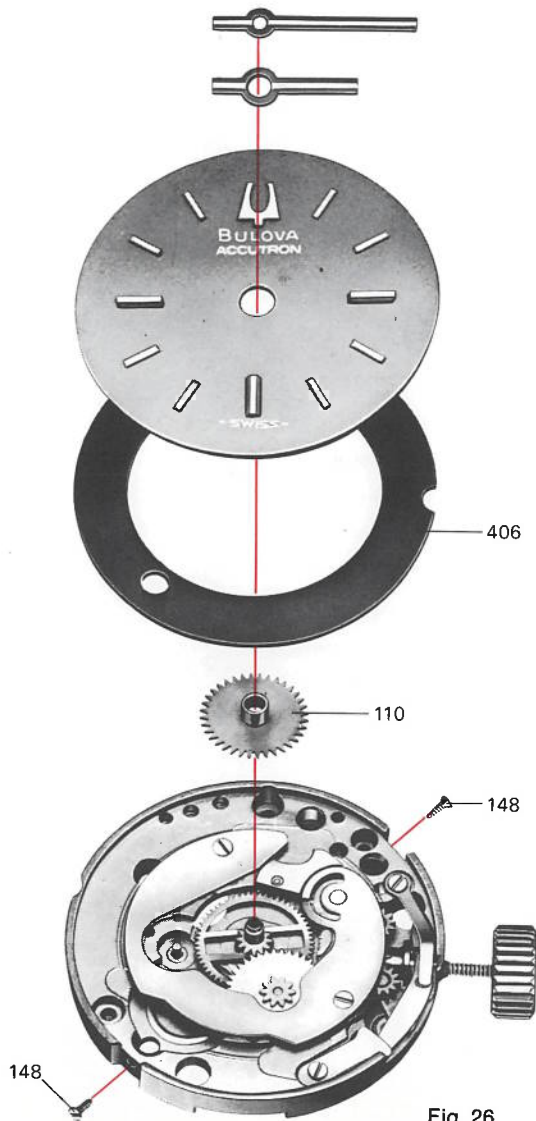

Fig. 26

Disassembly of Dial Train

CAUTION: CLEAN WORK AREA AND CASE BACK BEFORE OPENING CASE.

1. Remove case back as instructed on page 4.
2. Remove movement from case as follows:
The movement is usually held in place by 2 case clamps (902) and 2 screws (901). Release clamps. (Fig. 25).
3. To remove the stem, pull to setting position and press down on the set lever pin. Remove stem.
4. Remove movement from case. Remove hands. On sweep models take care not to turn sweep hand.
5. Remove both dial screws (148), dial, hour wheel (110) dial support ring (406) and dial washer (if there is one). (See fig. 26).
6. Disassembly of basic model setting mechanism.
 - A. Remove setting cover (150), minute wheel (111), cannon pinion with its wheel (109), setting wheel for minute wheel (215), setting lever pressure spring (210), setting lever spring (219), setting stem (176), setting lever (206), setting pinion (227), rocking bar assembly (144), large setting wheel (119) and screw (311). (Fig. 27).

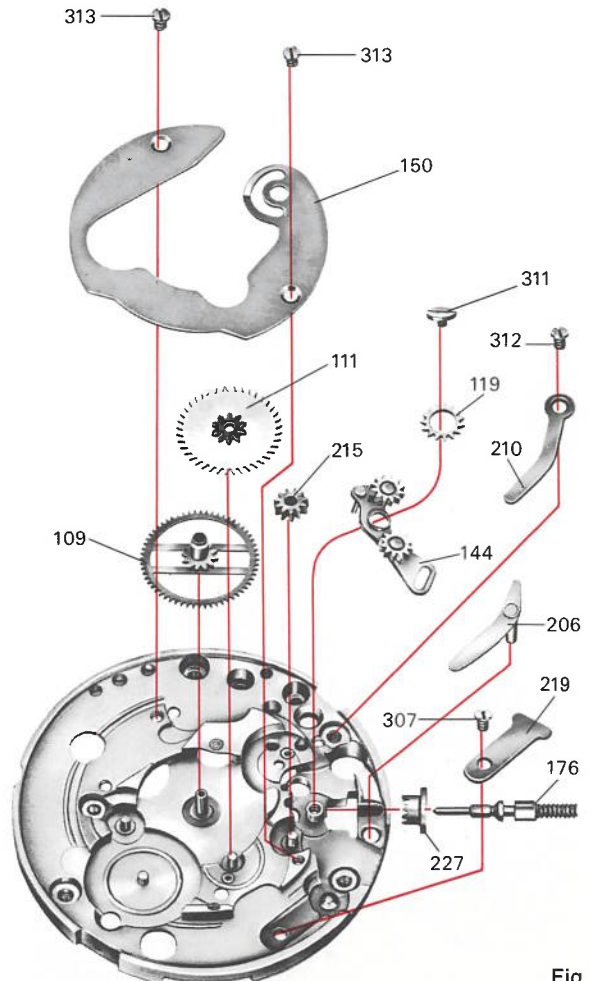

Fig. 27

Disassembly of the Gear Train

The coil assembly can be removed and replaced without disturbing the train, fork or indexing mechanism.

Unscrew coil assembly ground screw (151) and cell strap screw (304), remove cell strap (141) and turn the coil assembly (711) toward the outside of the movement. Remove coil assembly.

1. Using collet tool #9981 disengage index and pawl fingers from index wheel.
2. Disassembly of train:
 - a. Remove the two screws (125) and the train bridge (404).
 - b. Remove all wheels (112, 103, 105) with the exception of the 4th wheel (107). (Fig. 28).

Note: Carefully grasp the index wheel by its pinion, never by its rim and put pinion in pithwood to protect index wheel teeth from possible damage. Index wheel holder (page 12) can be used for cleaning. (Fig. 31)

- c. Remove screw (310) and ground plate (212).
3. Disassembly of tuning fork and coil assembly.
 - a. TURN COLLET OF THE INDEX FINGER PARALLEL TO THE TUNING FORK TINE. (Fig. 29). This is to make the pawl bridge accessible for removing.
 - b. Remove tuning fork (716), and fork spacer (186), 4th wheel (107), phasing screw (184), pawl bridge screw (181), pawl bridge (180 A) and index wheel guide (405). (Fig. 30).

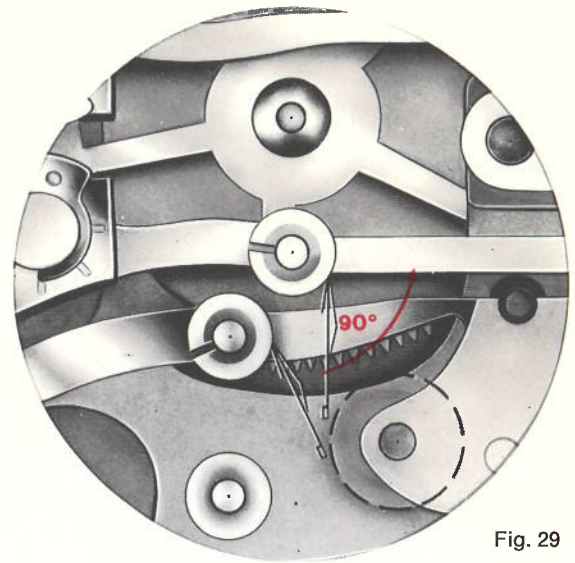

Fig. 29

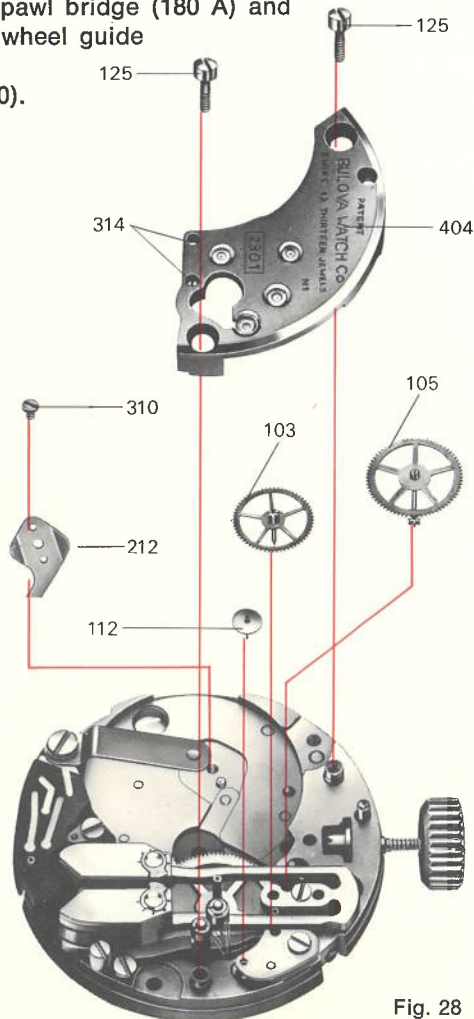

Fig. 28

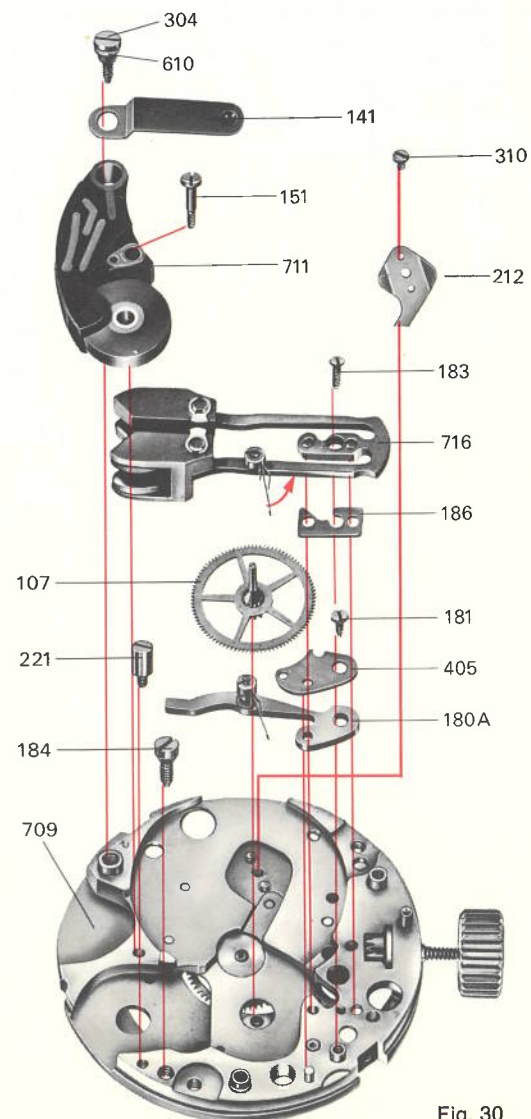

Fig. 30



Fig. 32

The Bulova WT Ultrasonic Watch Cleaner

Dependable, efficient, durable, economical.

The WT Ultrasonic Watch Cleaner can service up to six disassembled or partly disassembled watches at one time. It incorporates an automatic timer switch and forced air dryer. Magneto-strictive transducers insure a faster cleaner job. It enables you to get maximum mileage out of your cleaning and rinsing solutions. The WT Ultrasonic Watch Cleaner can truly be called the watchmaker's work horse.

Check these features:

- Three ultrasonically activated cups capable of handling up to six watches: at one time.
- Stainless steel baskets and small parts (mesh) containers for long life.
- Automatic pre-set timer for convenient and economical operation.
- Designed to use a minimum amount of solution.
- Forced warm air dryer for uniform drying of all parts.

(See fig. 32)

For further information write to:
WATCHMASTER PRODUCTS
Div. of Bulova Watch Company, Inc.
62-10 Woodside Ave.
Woodside, N.Y. 11377

Cleaning the Movement

With a few exceptions, this movement is treated like any other good quality watch movement.

Caution: Remove all metal particles from cleaning and rinse solution containers by means of a magnet. The following parts must *not* be cleaned in a machine because of possible damage.

1. The coil assembly (711)
2. The tuning fork with finger (716)
3. The pawl bridge with finger (180A)
4. The dial support ring (406)
5. The cell strap screw insulator (610)
6. The date ring (576)

The coil assembly, dial support, and date ring should be cleaned by a dry method (e.g. camel hair brush) not in a cleaning machine. Cap jewels are not disassembled and can be ultrasonically cleaned as is. Tuning fork and pawl bridge can be cleaned by dipping in benzine or cleaning solution, then using the proper rinse, and by blowing parts dry with an air blower. Check same after cleaning. Magnets and tines of tuning fork must be *absolutely clean*. All foreign matter which stays on the magnet must be removed (with masking tape or similar substance.) The cannon pinion must not be separated from its wheel but cleaned together. After cleaning, avoid turning the wheel until proper lubrication is applied (OL 207). The index wheel must be ultrasonically cleaned with caution in order to prevent damage to its teeth. It is recommended that the index wheel be placed between pillar plate and train bridge and cleaned as an assembly in cleaning machine or placed in index wheel holder* and cleaned.

*Index wheel holder is available through an Authorized Bulova Material Distributor. Fig. 31.



Fig. 31

Recommended Lubricants:

- (V) Moebius OL 219 (Synta Visco Lube 9020)
- (M) Moebius OL 207 (Special Lubricant with Molybdenum Disulphide 8201)

Check page 13.

Reassembly of the Gear Train

In the following reassembly procedures, important lubrication instructions are required for the ACCUTRON Series 230. These are the same lubricants used for the ACCUTRON Series 214 and Series 218, which are as follows:

- (V) Moebius OL 219-Synta Visco Lube (Moebius 9020)
- (M) Moebius OL 207-Special Lubricant with Molybdenum Disulphide (Moebius 8201)

Both lubricants are available at your Materials Distributor.

1. Lubricate (V) the index wheel pivot jewels, 2nd wheel jewel (pillar plate). (Fig. 33).
2. Reassemble the pawl bridge 180A, retaining plate (405), phasing screw (184) and 4th wheel (107).
3. Reassemble the coil safety screw (221), tuning fork (716) with its spacer (186), coil assembly (711), cell strap (144) with its screw (304) and insulator (610) and ground screw (151).

Note: Before installing the train make sure the index finger is reset at a right angle to the tuning fork tine. (Fig. 34).

Note: The space between the fork cup and pillar plate should be 0.10 mm ($\frac{1}{4}$ the thickness of the tuning fork cup without magnets). Spacers of different thicknesses are available and are used to attain this spacing. They are recognizable by the following:

- RED — 0.23 mm
- YELLOW — 0.20 mm
- WHITE — 0.17 mm

The coil must be centered between the magnets. To check, using pegwood press down on tuning fork cup. The fork must touch the pillar plate and must not touch the coil. Replace spacer if necessary. (Fig. 35).

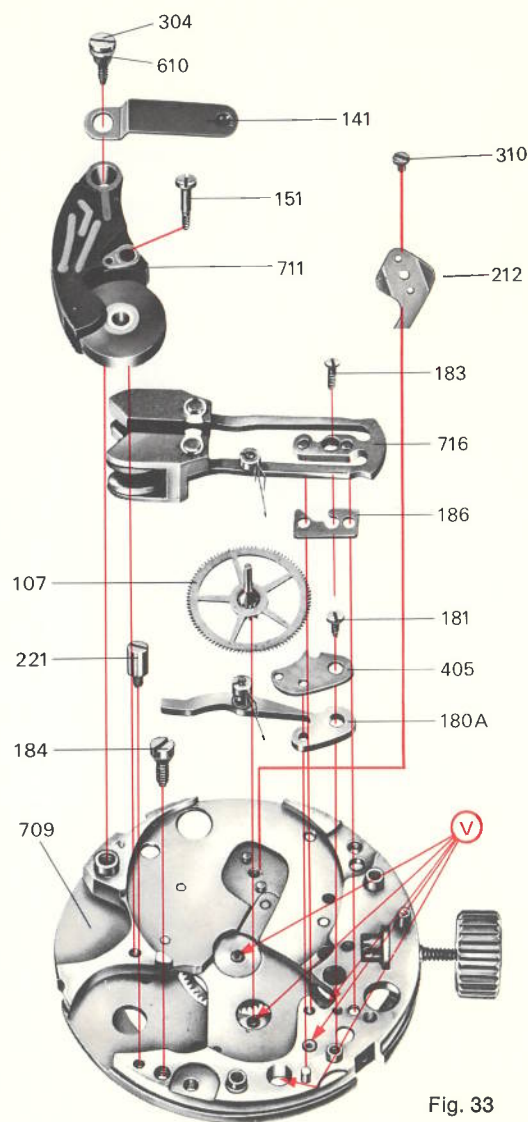

Fig. 33

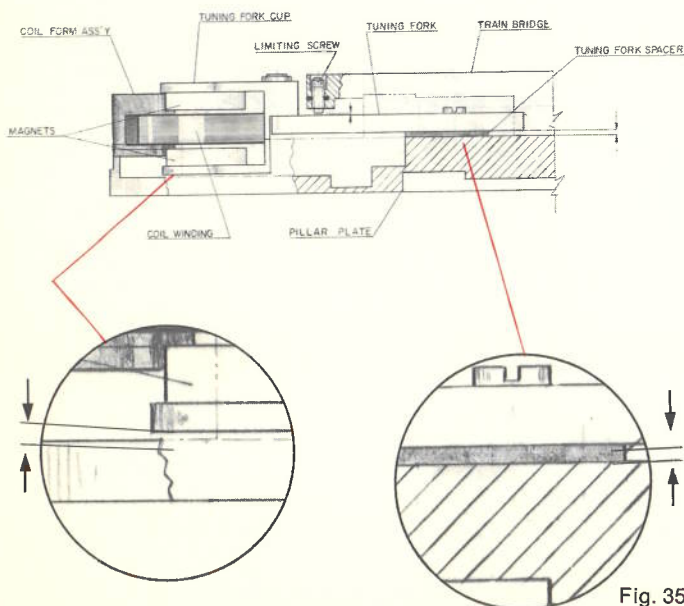

Fig. 35

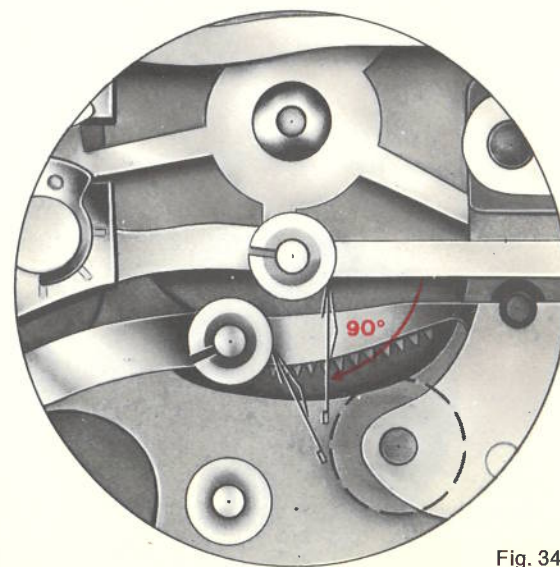

Fig. 34

Meter Testing of the Coil and for Free Fork

Before assembling train, check for power consumption with the selector switch of test set at "READ MICROAMPERES". Stem must be "in" to release hack mechanism. Meter pointer must stay below 7 microamperes. (If above 7 microamperes check for "EXCESSIVE CURRENT" problems. Page 9).

Checking and adjusting the Hack Mechanism

1. Disconnect the Test Meter Cell lead.
2. Pull stem out to setting position and observe if the hack pin pushes against the fork tine. If it does not, the hack pin is too far away from the fork tine and must be brought closer by slightly bending the pin towards the tine using tool # 22009. This engagement is properly adjusted when a slight movement of the tine is observed as the pin pushes against it when the crown is pulled out or to setting position.

With the crown "in" the minimum distance between the hack pin and the tuning fork tine must be equal to half the thickness of the hack pin. With the Test Meter Power Cell lead connected to the movement, pull the crown out to setting position. The hack pin must block the tuning fork. The meter pointer should show "EXCESSIVE CURRENT" (pegs). The fork should start within five seconds of the crown being pushed "in" or running position. If it does not start, recheck the hack adjustment (fig. 36).

Installation of Wheels and Bridge

- A. Lubricate (V) Bridge jewels (fig. 37).
ATTENTION: Before continuing the following operation, make sure the index and pawl fingers are turned away from the index wheel area.
- B. Install train wheels in order (103, 105, 112).
- C. Check endshake and freedom of train.
- D. To check friction of center wheel assembly, pull stem into setting position and turn crown. The train must turn otherwise the center wheel assembly (109) (sweep model 579) is too loose and must be replaced. DO NOT ATTEMPT TO TIGHTEN.

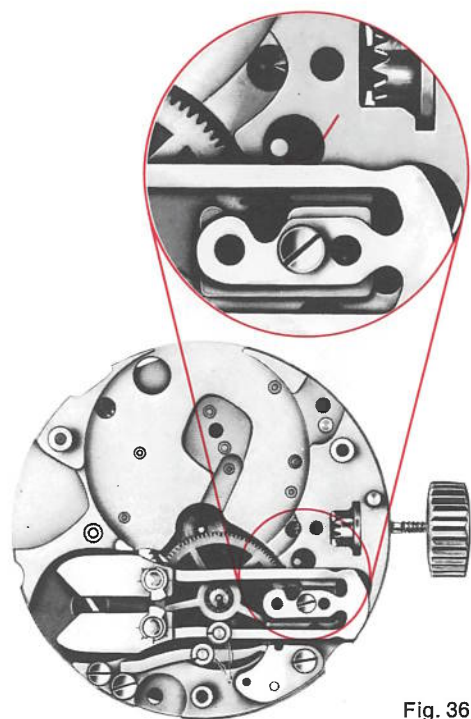

Fig. 36

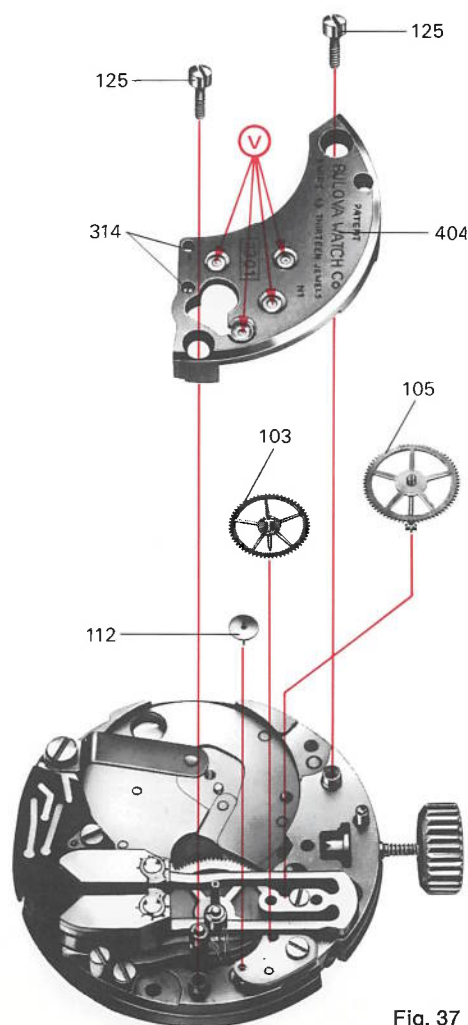

Fig. 37

Adjusting the Tuning Fork Clearance.

The space between the limiting screws (314) and tuning fork tines must be from 0.05 to 0.07 mm. To obtain correct spacing:

- A. Connect test set to movement turning selector knob to "READ MICROAMPERES".
- B. Turn "in" one limiting screw (314) clockwise, until the pointer on the meter test set shows excessive current (pegs) indicating blockage of tuning fork.
- C. "Back off" screw by half a turn. This provides proper clearance (0.05 to 0.07 mm).
- D. Check fork clearance by lifting tuning fork with peg-wood until its tine touches the limiting screw. Make sure magnet *does not touch coil* before tine touches limiting screw. (Fig. 38).

Repeat operation B and C on opposite limiting screw. Check as in D.

Note: The limiting screws 314 are usually screwed through a thin piece of synthetic material 228 in the train bridge. If insert was not used, and screws go directly through the bridge, it will be necessary to apply a small drop of clear lacquer into the screw holes *after* adjustment to prevent movement of screws. This has to be done every time the screws have been displaced or cleaned.

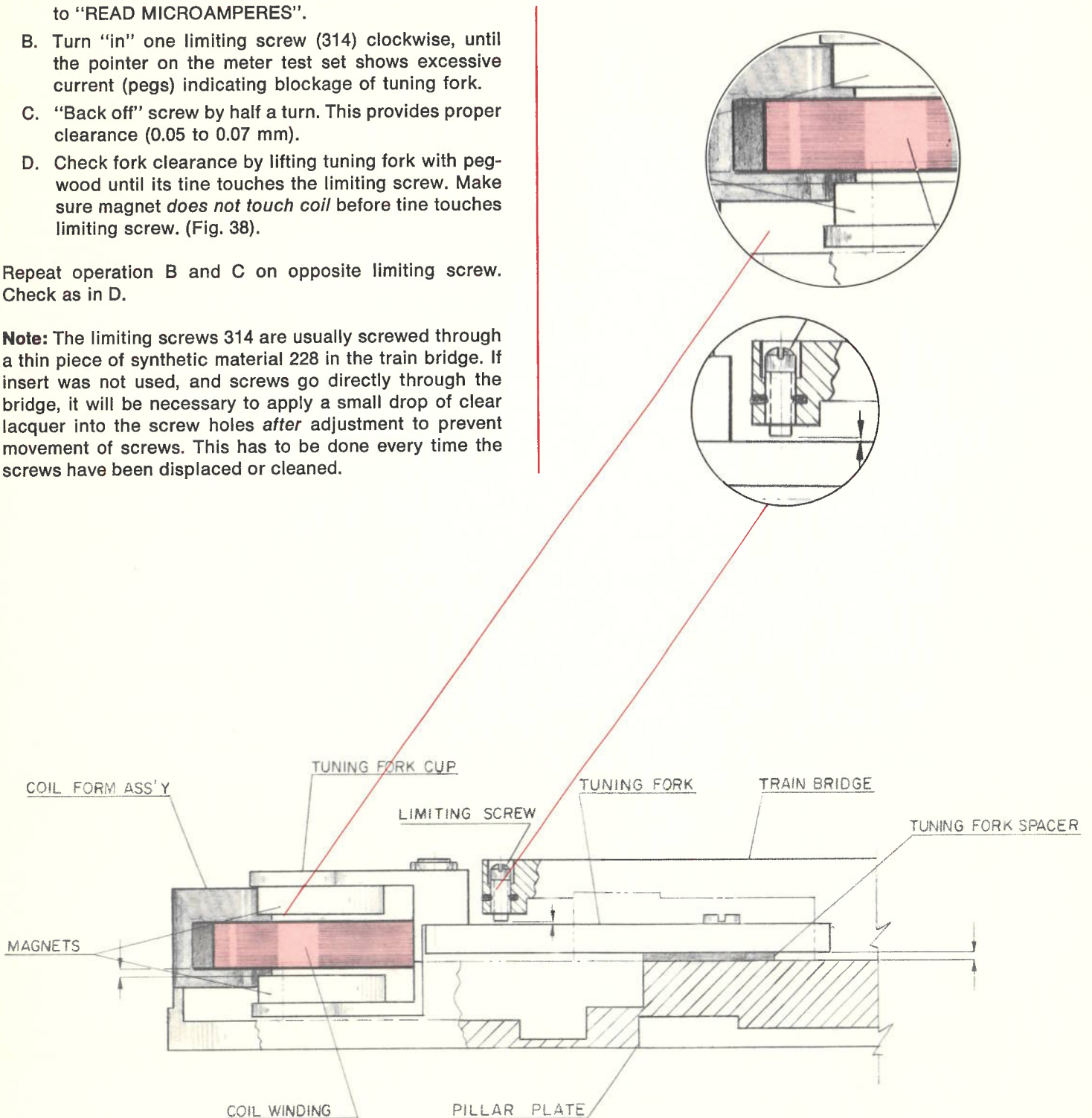

Fig. 38

Lubricating Dial Train

Only the following lubricants are recommended and should be used very sparingly:

(V) Moebius 9020—(OL 219) Synta Visco Lube

(M) Moebius 8201—(OL 207) Special lubricant with Molybdenum disulfide

These lubricants are available at your Material Distributors

Assembling Dial Train

1. Reassembling of the dial side mechanism. (Fig. 39).
 - a. Lubricate (M) setting stem, rocking bar assembly (144), setting level pin (206), friction point of setting lever and its spring (219).
 - b. Assemble: rocking bar (144), setting pinion (227), setting stem (176), setting lever (206), setting lever spring (219), setting level pressure spring (210), centered on setting level, setting wheel (119), screw (311), setting wheel for minute wheel (215).
 - c. Lubricate: (M) cannon pinion with its center wheel (109) 2300 (579—2301 & 2302).
 - d. Lubricate: (M) center tube, and post for setting wheel.
 - e. Lubricate: (V) intermediate setting wheels on #144.
 - f. Assemble: cannon pinion and wheel (109/579), setting cover (150).
2. Fitting the hour wheel, dial and hands.
 - a. Assemble: Hour wheel (110) and dial washer (if there is one), dial support ring (406) dial and screws (148). (Fig. 40).
 - b. Pull stem into setting position.
 - c. Assemble: Hour and minute hands supporting the center tube with movement support E 32.

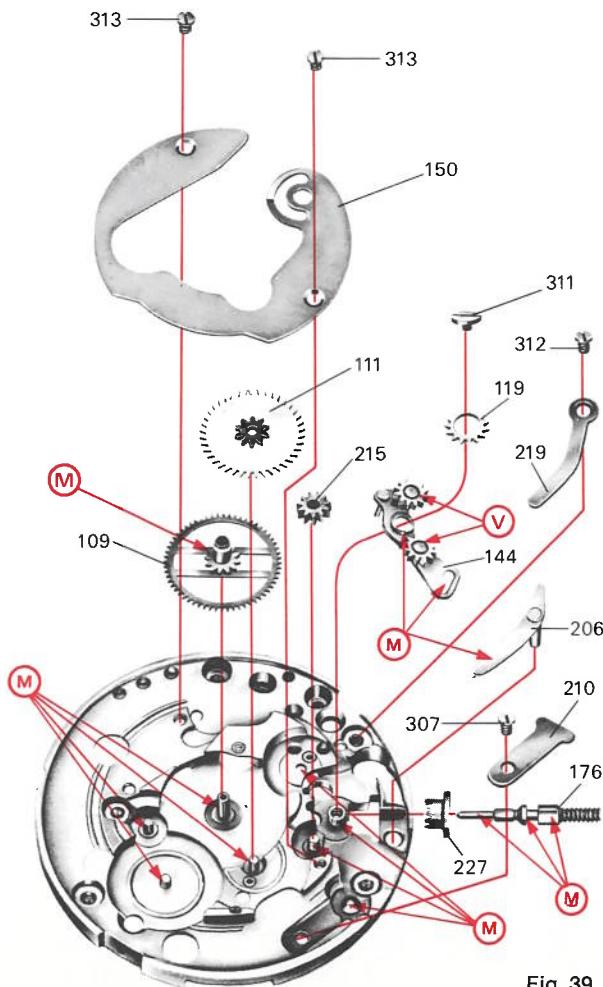

Fig. 39

FOR OTHER MODELS SEE SUPPLEMENT AT THE REAR OF THE MANUAL

Certain Accutron models (2300 and 2301) are fitted with dome dials. In these models the dial support ring (406) is replaced by a special part, namely: Retainer plate for setting pinion (229).

Function To hold the setting pinion (227) and setting lever (206) in place when the setting stem (176) is being removed.

Positioning The position of the retainer plate for setting pinion (229) is determined by the cut-outs made for the dial feet. (Fig. 41).

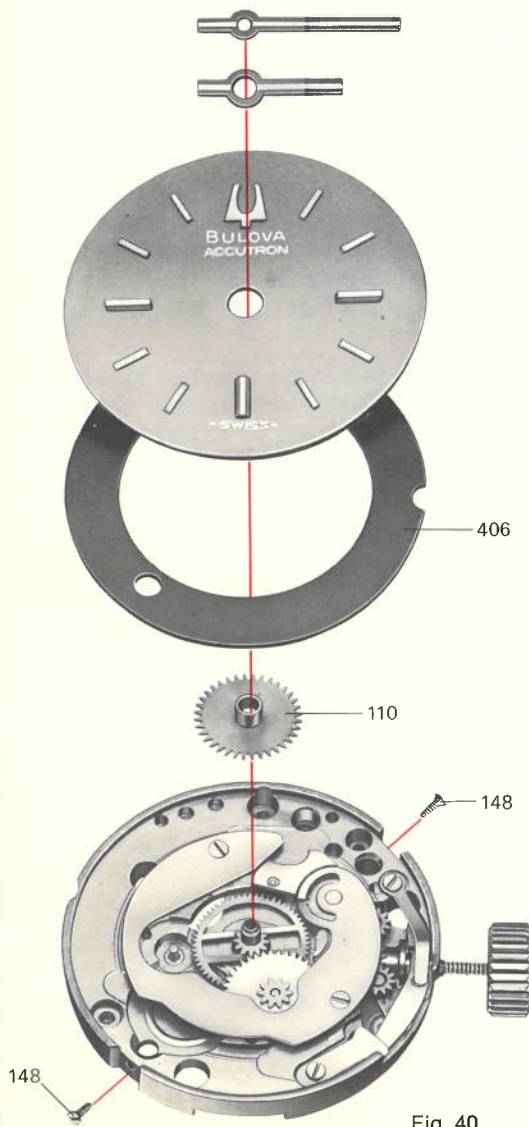

Fig. 40

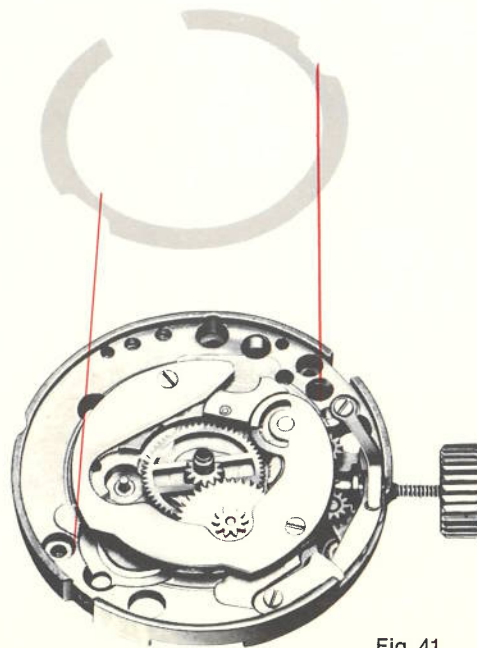

Fig. 41

Adjusting Indexing Mechanism

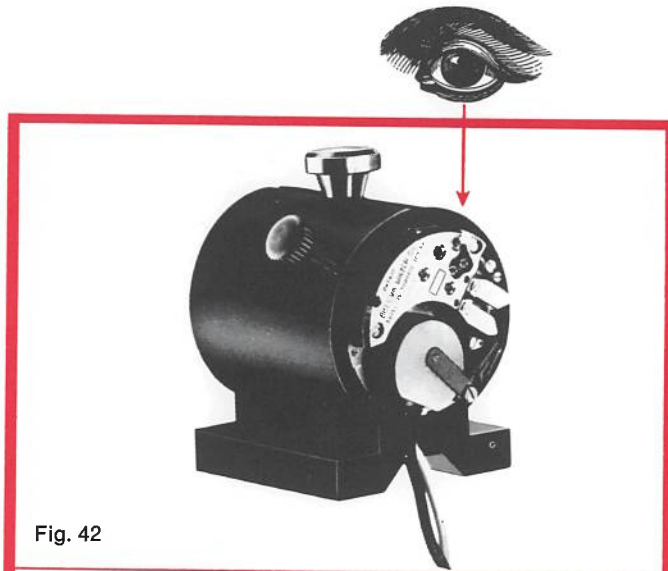

Fig. 42

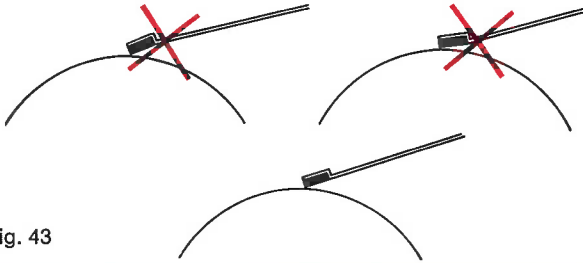

Fig. 43

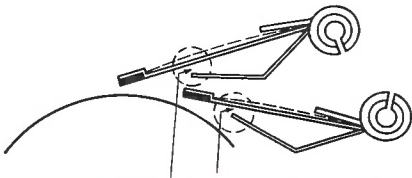

Fig. 44

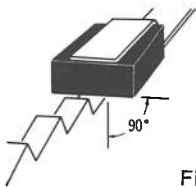

Fig. 45

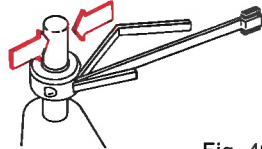

Fig. 46

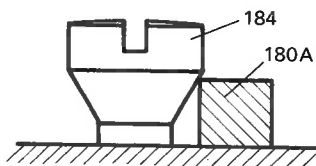

Fig. 47

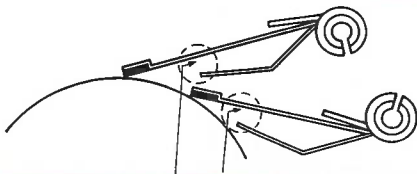

Fig. 48

1. Make sure stem is pushed "in" (running position). For proper sighting of fingers under microscope, place movement in the movement holder and stand holder on end. (See fig. 42). Check fingers in horizontal position—sighting through edge of movement at index wheel position.
2. The contact surfaces of the index and pawl jewel must be parallel to their fingers (see fig. 43). Before engaging verify that fingers are slightly curved (see fig. 44). The two jewels must be perpendicular to the axis of the index wheel (fig. 45). To adjust, grasp finger and stress limiter as close as possible to the collet and bend slightly. The height of the jewel in relation to the index wheel, is adjusted by bending the posts. The teeth of the index wheel must be in the center of each jewel. If necessary, correct by bending finger posts (fig. 46) with tool #22010.
3. Check stress limiters on index and pawl finger. Make sure the end of the stress limiter is away from its finger by not more than 2 times its thickness nor less than one thickness before engagement. (Fig. 44).

Preposition and Engagement of Index and Pawl Fingers

1. Turn index finger collet until jewel is completely disengaged from wheel. Check gap between gage and index finger (fig. 44). The gage should be AS CLOSE AS POSSIBLE but not touching the finger. Adjust by bending gage near collet to a maximum of one finger thickness.
2. Engage index jewel into index wheel by turning collet with adjusting tool (E 9981) until the gap between the gage and finger is INCREASED BY A DISTANCE EQUAL TO 1 THICKNESS OF THE INDEX JEWEL more than the initial setting during step 1. (Fig. 48).
3. The engagement of the pawl finger is accomplished in the identical manner as step 3.
4. Steps 3 and 4 introduce the proper tension of the fingers against the index wheel.
5. Adjust phasing screw to proper pre-phasing position by turning screw *clockwise* until the top of the pawl bridge is lined up with the top of the angle of the phasing screw. (Fig. 47)

Phasing

1. Place the cell in the meter test set and check cell at "CELL TEST" setting.
2. Attach power cell lead to movement and turn selector switch to "LOW AMPLITUDE". If the tuning fork does not vibrate the test set will indicate high current. In this case tap movement holder lightly to start the vibration of the tuning fork. The phasing screw should be properly pre-positioned as described on page 18 par. 5.
3. Back off the phasing screw very slowly in a **COUNTER-CLOCKWISE** direction until the train turns without hesitation. The watch is now in phase. Unlike the phasing adjustment of the Accutron Models 214 & 218, the Series 230 is properly phased when the train wheels turn for the first time without hesitation. If the watch is clean and properly adjusted, the train should turn smoothly. If not, replace the index wheel and rephase. After the movement is properly phased turn the meter selector knob to "**READ MICROAMPERES**". The pointer of the meter should be below 10 microamperes.

Note: Phasing positions the pawl jewel in proper relation-ship to the index jewel by turning the phasing screw.

Casing of the Movement

Pull stem into setting position before casing and remove stem. Place movement in case and fit case clamps. The movement must not move inside the case, however the case clamps should not be too tight. (Fig. 49) Case clamps of different thickness are available and are distinguishable by their color. They are listed as follows:

BLACK	— 0.35 mm
BLUE	— 0.30 mm
ROSE	— 0.25 mm
YELLOW	— 0.20 mm
WHITE	— 0.15 mm
BLACK	— 0.10 mm

Checking Movement in Case

Important: Always check movement after casing.

After casing, connect the power cell meter lead once more and check the watch in the case. First set the meter selector knob at "LOW AMPLITUDE" and check that the train wheels are turning. If the train does *not* turn smoothly, rephase in the case by turning the phasing screw *counterclockwise* slightly. If the wheels will not turn smoothly at "LOW AMPLITUDE" in the case, then the casing clamps must be replaced with a set of the next size thinner. Again the movement must be held tightly in case. (Fig. 50).

Checking the Rate in the Case

Check the timing rate (frequency) on the Vibrograf rate recorder and regulate if necessary to "0" zero in dial position. A tolerance of +1 to -1 second a day is acceptable.

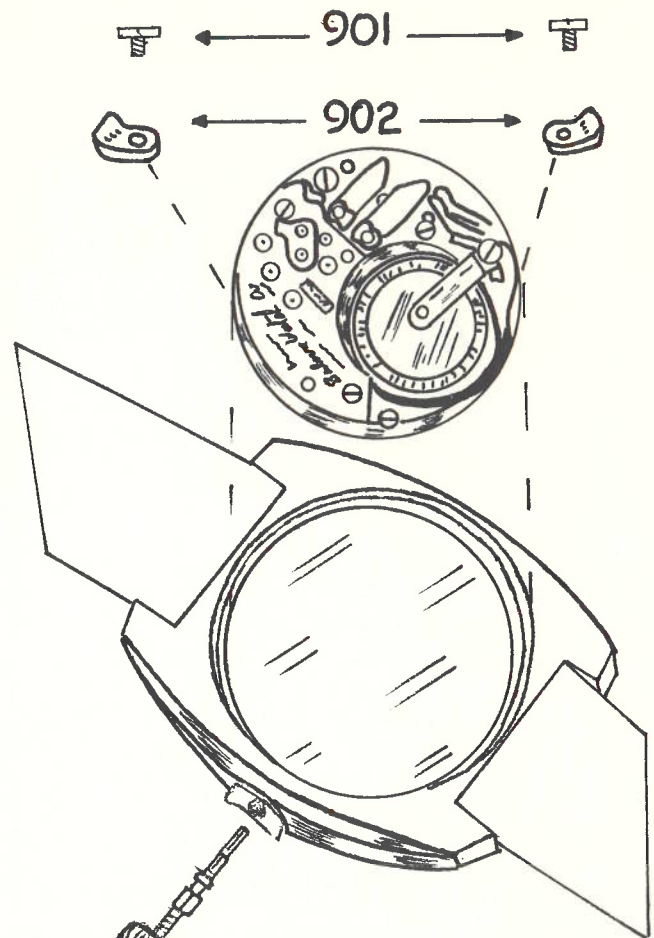

Fig. 49

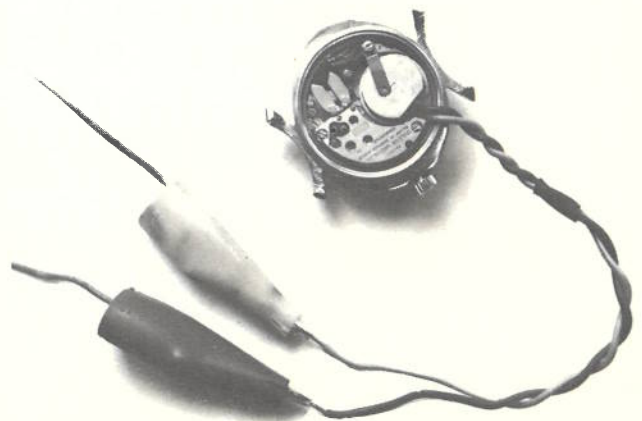

















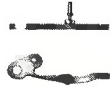



























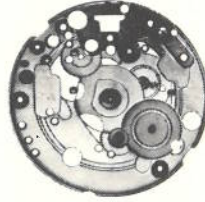
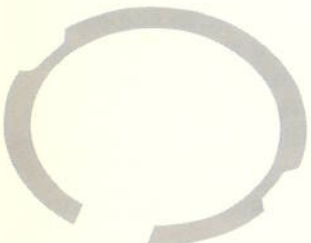













Fig. 50

Basic Parts List/Model 2300

 103 Second wheel	 139 Dial washer	 162 Power cell	 195 Upper jewel for fourth wheel
 105 Third wheel	 141 Cell strap	 172 Upper complete setting for index wheel	 196 Lower jewel for fourth wheel
 107 Fourth wheel	 142 Minute hand	 173 Lower complete setting for index wheel	 197 Upper jewel for second wheel
 109 Center wheel	 143 Hour hand	 176 Setting stem	 198 Lower jewel for second wheel
 110 Hour wheel	 144 Rocking bar assembly	 180A Pawl bridge	 199 Upper jewel for third wheel
 111 Minute wheel	 148 Dial screw	 181 Pawl bridge screw	 200 Lower jewel for third wheel
 112 Index wheel	 150 Setting cover	 183 Tuning fork screw	 206 Setting lever
 119 Setting wheel		 184 Pawl bridge phasing screw	 210 Setting lever pressure spring
 125 Train bridge screw	 151 Coil form ground plate screw	 186 Fork spacer	 212 Ground plate

 215 Setting wheel for minute wheel	 307 Setting lever pressure spring screw	 406 Dial support ring	<p>The following material is ordered by the number stamped inside the case back.</p> <p>Bezels Backs Gaskets Crystals Crowns</p> 
 219 Setting lever spring	 310 Ground plate screw	406 Dial support ring	
 221 Coil guard	 311 Rocking bar screw	 610 Insulator	
 227 Setting pinion	 312 Setting lever spring screw	 709 Pillar plate	
 229 Retainer plate for setting pinion	 313 Setting cover screw	709 Pillar plate	
	 314 Fork limiting screw	 711 Coil assembly	
 230 Index finger assembly	 404 Train bridge	 716 Tuning fork	
 231 Pawl finger assembly		 901 Case clamp screws	
 304 Cell strap screw	 405 Index wheel guide	 902 Case clamps BLACK — 0.35 mm BLUE — 0.30 mm ROSE — 0.25 mm YELLOW — 0.20 mm WHITE — 0.15 mm BLACK — 0.10 mm	

SECTION III

Model 2301 (Sweep Second)

All information and instructions contained in Sections I and II of this service manual are also applicable to the Model 2301. On this page you will find illustrations and explanations regarding Model 2301. A parts list pertaining to this model is below. (Fig. 51).

1. Fitting of hour wheel, dial and hands:

- A. Install hour wheel and dial washer, if required, and dial screws (2)-(148)
- B. Install hour and minute hand using movement support #E 32.
- C. Stem must now be placed in "In" position.
- D. Turn selector switch of test meter set to "READ MICROAMPERES". Check and note power consumption for future comparison. *Caution:* Turning the sweep second hand or gear train in either direction, with the Indexing fingers engaged, will damage the Index wheel teeth or Index and Pawl Fingers.
- E. Install sweep second pinion (158) and oil (V). (fig. 52).
- F. With the movement still in dial down position place movement support #E 31 **over** movement and then turn both movement and holder **dial up** to apply sweep second hand to pinion.
- G. Install friction spring (212) and make sure that the part holding the pinion in place is parallel to the pillar plate (fig. 53).
- H. With the selector switch on "READ MICROAMPERES" check power consumption again and compare to previous reading at "d". If the difference is greater than 0.5 (1/2) of a microampere reduce tension of spring. If the difference is less than 0.1 (1/10) of a microampere increase tension of friction spring.
- I. Turn selector switch to "LOW AMPLITUDE" and check for running without hesitation. Rephase if necessary. (see page 19).

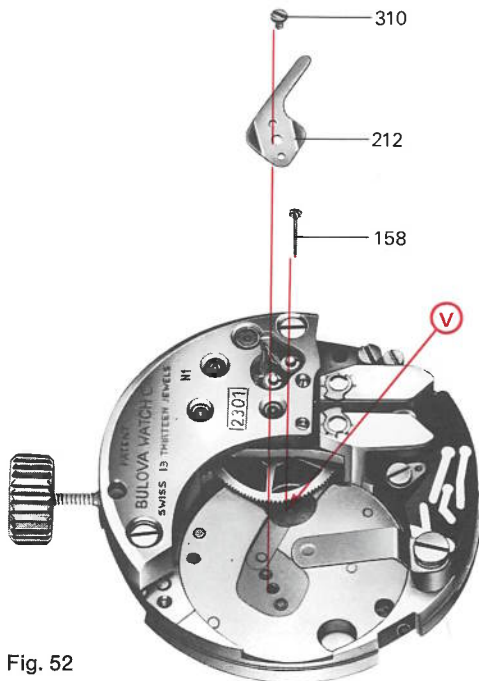

Fig. 52

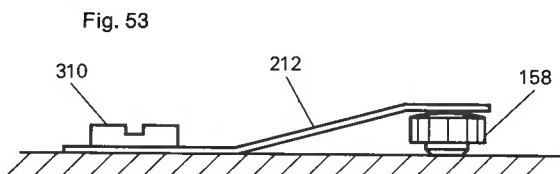

Fig. 53

Parts List Model 2301 (fig. 51)

All other parts same as basic Series 230.

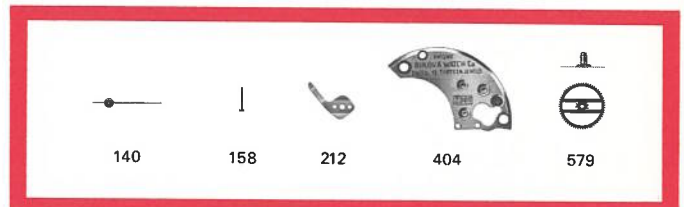

Fig. 51

- 140 Sweep second hand
- 158 Center second pinion
- 212 Ground plate and friction spring for sweep second
- 404 Train bridge
- 579 Center Wheel

Model 2302 (Calendar)

SECTION IV

All information and instructions contained in previous sections of this maintenance manual are also applicable to Model 2302. In the following pages you will find illustrations and instructions regarding the disassembly, assembly and lubrication of the date mechanism Model 2302. A parts list is on page 24.

1. Disassembly of date mechanism and setting train.

- A. *Remove:* intermediate date wheel (584), 2 screws (313), setting cover (150), date indicator detent spring (573), date indicator detent (572), date ring (576), date corrector wheel (569), minute wheel (111), cannon pinion and its wheel (579), date trip wheel (574), setting wheel for minute wheel (215).

2. Reassembly of date mechanism and setting train

- A. *Lubricate:* (M) cannon pinion and its wheel (579), the center tube setting wheel for minute wheel (215), the post of the date jumper wheel, the post of the date corrector wheel.

- B. *Install:* date trip wheel (574), cannon pinion and wheel (579), minute wheel (111), setting wheel for minute wheel (215), date corrector wheel (569), date ring (576), detent spring (573), date detent (572).

Note: Lightly lubricate the finger of date trip wheel (574). Install: setting cover (150), 2 screws (313), intermediate date wheel (584). (fig. 54).

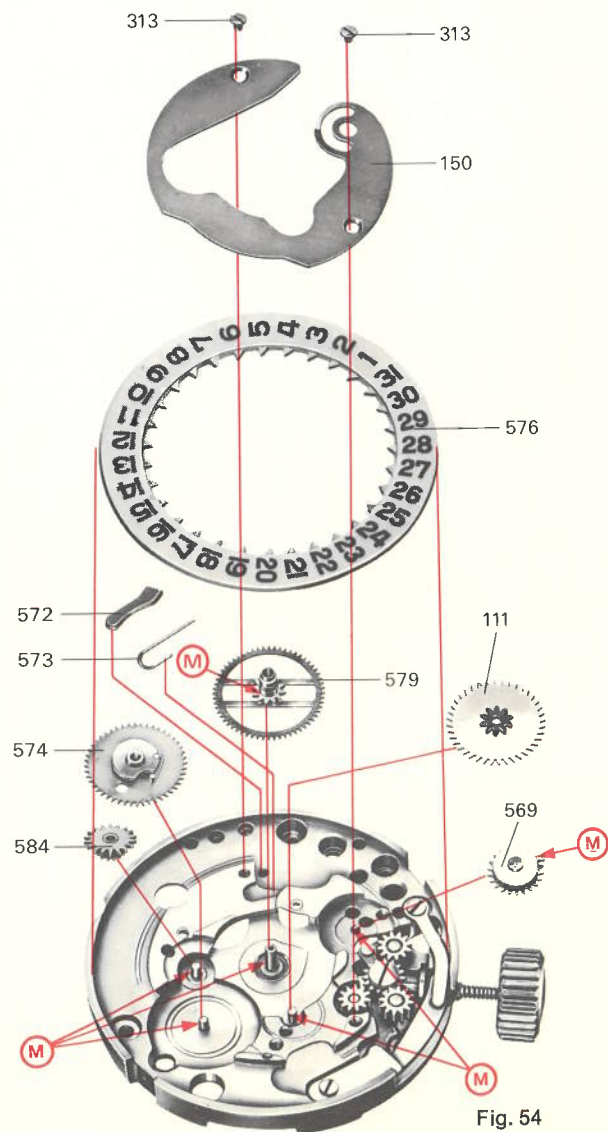

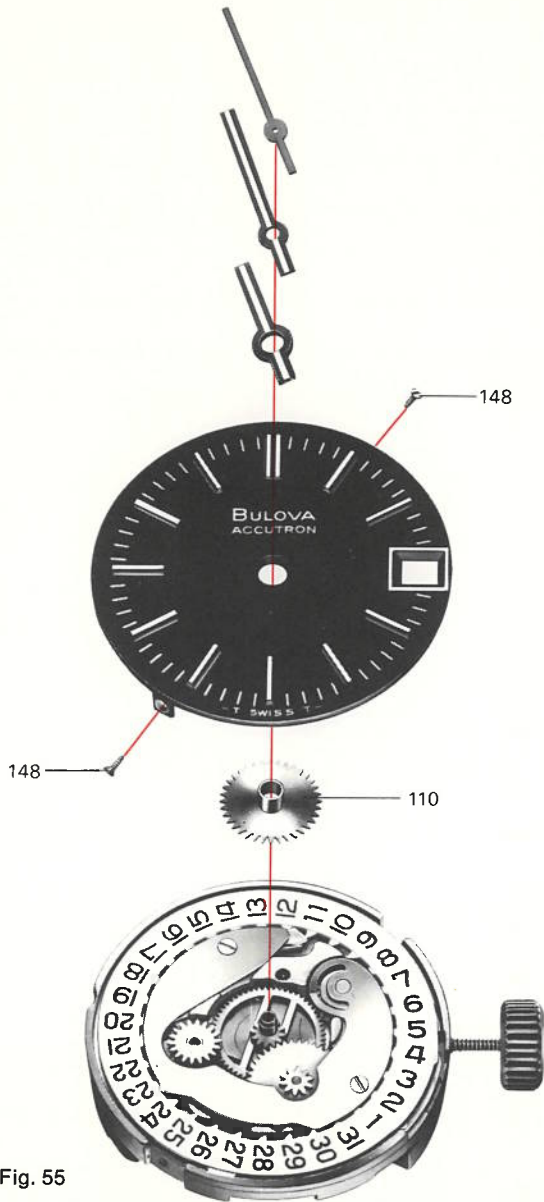
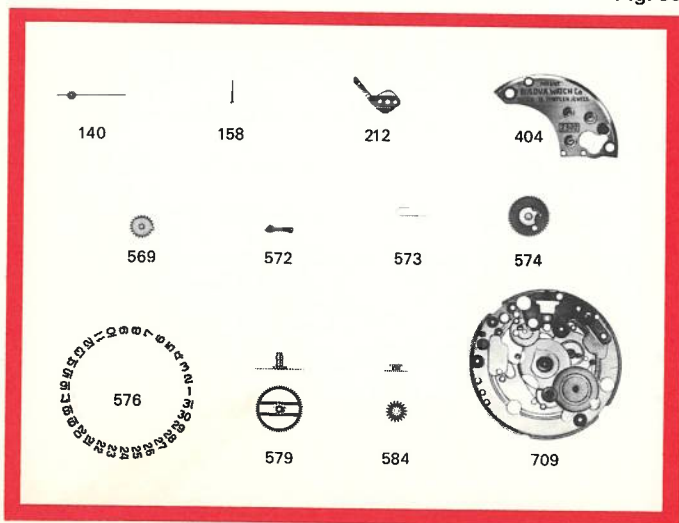

Fig. 55

Fig. 56



3. Assembly of the hour wheel, dial and hands.
 - A. Install wheel (110) and dial washer if required, dial and two screws (148). (fig. 55).

Note: To assure the proper functioning of the date change, the dial must be fitted since it limits the vertical displacement of the date corrector (569).
 - B. Pull stem into setting position and turn slowly until date jumps.
 - C. Fit hour and minute hands at the 11:58 position (2 minutes before 12:00) using movement support #E 32.
 - D. Stem must now be pushed to "In" position.
 - E. Turn selector switch of test meter set to "READ MICROAMPERES" and note power consumption for further comparison.

Caution: Turning the sweep second or gear train in either direction, with the Indexing fingers engaged, will damage the Index wheel teeth or Index and Pawl fingers.

 - F. Install sweep second pinion (158) and oil (V).
 - G. With the movement still in dial down position place movement support #E 31 over movement and then turn both movement and holder dial up to apply sweep second hand to pinion.
 - H. Install friction spring (212) and make sure that the part holding the pinion in place is parallel to the pillar plate (fig. 53).
 - I. With the selector switch on "READ MICROAMPERES" check power consumption again and compare to previous reading at "E". If the difference is greater than 0.5 (1/2) of a microampere, loosen friction spring. If the difference is less than 0.1 (1/10) of a microampere increase tension of friction spring.
 - J. Turn selector switch to "LOW AMPLITUDE" and check for running without hesitation. Rephase if necessary (see page 19).
To change date instantly, crown must be in "IN" and turned *counterclockwise*.

Parts List Model 2302 (fig. 56).

All other parts same as basic Series 230.

- 140 Sweep second hand
- 158 Center second pinion
- 212 Ground plate and friction spring for sweep second
- 404 Train bridge
- 569 Date corrector
- 572 Date indicator detent
- 573 Date indicator detent spring
- 574 Date trip wheel
- 576 Date indicator
- 579 Center wheel
- 584 Intermediate date wheel
- 709 Pillar plate

PRINTED IN U.S.A.